

Unit: mm

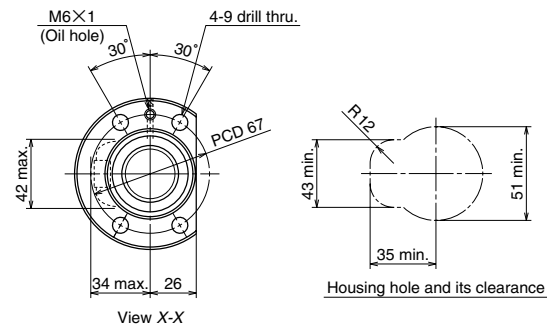

Ball screw specifications			
Product classification	Preloaded	Precise clearance	
Shaft dia. x Lead / Direction of turn	32 x 32 / Right		
Preload / Ball recirculation	P preload / Return tube		
Ball dia. / Ball circle dia.	4.762 / 33.25		
Effective turns of balls	1.5 x 1		
Accuracy grade / Axial play	C5/Z	C5/T	
Basic load rating (N)	Dynamic $C_d$	8800	11500
	Static $C_0$	16600	24800
Axial play	0	0.005 or less	
Dynamic friction torque, (N · cm)	6.9~31.5	~7.8	
Spacer ball	Yes	None	
Factory packed grease	NSK grease LR3		
Internal spatial volume of nut (cm <sup>3</sup> )	14		

Unit: mm

Ball screw No.		Stroke	
		Nominal	Maximum (L <sub>1</sub> -Nut length)
Preloaded (LPFT)	Precise clearance (LSFT)		
<b>W3211FA-3P-C5Z32</b>	<b>W3211FA-4-C5T32</b>	1000	1071
<b>W3216FA-3P-C5Z32</b>	<b>W3216FA-4-C5T32</b>	1500	1571
<b>W3221FA-3P-C5Z32</b>	<b>W3221FA-4-C5T32</b>	2000	2071
<b>W3227FA-3P-C5Z32</b>	<b>W3227FA-4-C5T32</b>	2600	2671

Screw shaft length			Lead accuracy			Shaft run-out**	Mass (Kg)	Permissible rotational speed N (min <sup>-1</sup> )	
L <sub>1</sub>	L <sub>2</sub>	L <sub>3</sub>	T	e <sub>p</sub>	v <sub>u</sub>			Supporting condition	
								Fixed - Simple support	Fixed - Fixed
1180	1219	1376	0	0.046	0.030	0.090	9.3	2180	2180
1680	1719	1876	0	0.065	0.040	0.120	12.3	1570	2180
2180	2219	2376	0	0.077	0.046	0.160	15.4	920	1290
2780	2819	2976	0	0.093	0.054	0.200	19.1	560	790

- Remarks
1. We recommend NSK support unit WBK25-01 (square type, fixed side), and WBK25S-01 (square type, simple support side), and WBK25-11 (round type, fixed side).
  2. NSK grease LR3 is recommended. The amount for replenishing should be about 50% of the nut internal space capacity.
  3. Permissible rotational speed is determined by a  $d \cdot n$  value and a critical speed. See page B509. Root diameter of screw shaft (dr) is 28.3 mm.