

A-1-5 直線滑軌之尺寸表和公稱型號

A-1-5.1 LH 系列



圖 I-5-1 LH 系列

(1) 自動調芯性（橫向）大

如同旋轉軸承的 DF 組合，接觸線交點位於內側，力矩剛性小，故調芯性大。

這樣就增加了對安裝誤差的吸收能力。

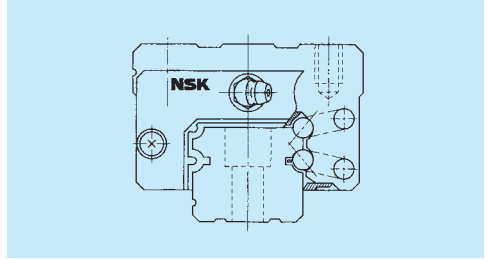
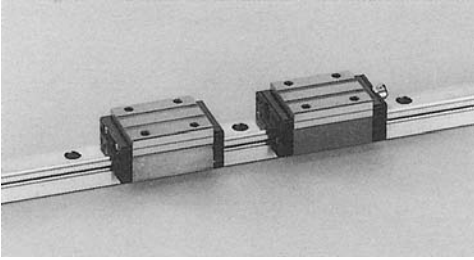
(2) 下方向負載能力強

因將接觸角度設為 50° ，故增加了上下方向之負載能力和剛性。



圖 I-5-2 溝槽放大圖（偏移哥德式溝槽）

(3) 耐衝擊能力強

因下側滾珠溝槽係哥德式溝槽形狀，偏移了槽的中心，故通常為 2 點接觸。但當由上方產生高負載時，通常非接觸面也承受負載。

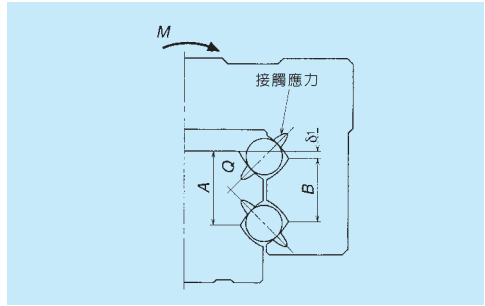

圖 I-5-3 負載狀態

(4) 高精度

對於哥德式溝槽形狀，如圖 I-5-4 所示，容易固定測量滾輪，故能便捷準確地對滾珠溝槽進行精度測量。

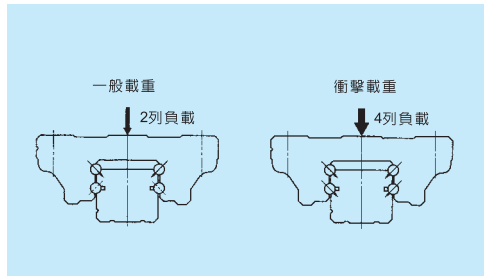

圖 I-5-4 滑軌的研磨和測量

(5) 擁有互換性產品系列（短交期）

作為標準庫存品，備有滑軌和滑塊等任意調換的互換性產品，故交期短。

(6) 使用方便的安全設計

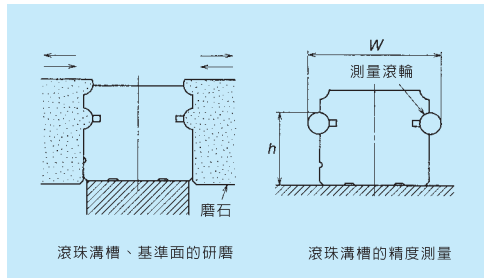
即使將滑塊從滑軌中抽出，因滾珠受保持器的保護，故不會脫落。

(7) 規格尺寸齊全之系列化產品

各系列產品均擁有形狀多端的滑塊，故能適應多種機種。

LH系列 (預壓保證品)

LH系列尺寸表 (預壓保證品)

LH-AL (大負載型)

LH-AN (大負載型)

LH-BL (超大負載型)

LH-BN (超大負載型)

· 預壓保證品的連絡編號 (訂貨生產)



表 I-5 · 1

規格	組裝品尺寸			滑塊尺寸																		
	高度	寬度	長度	安裝螺絲孔			安裝螺絲孔	安裝螺絲孔	安裝螺絲孔	安裝螺絲孔	安裝螺絲孔	油嘴										
				安裝螺絲孔	安裝螺絲孔	安裝螺絲孔						安裝螺絲孔	安裝螺絲孔	安裝螺絲孔								
H	E	W ₂	W	L	B	J	M×間距×l	B ₁	L ₁	J ₁	K	T	安裝孔	T ₁	N							
LH15AN	28	4.6	9.5	34	55	26	26	M4x0.7x6	4	39	6.5	23.4	8	φ3	8.5	3.3						
LH15BN					74					58	16											
LH20AN	30	5	12	44	69.8	32	36	M5x0.8x6	6	50	7	25	12	M6x0.75	5	11						
LH20BN					91.8		50			72	11											
LH25AL	36	7	12.5	48	79	35	50	M6x1x6	6.5	58	11.5	29	33	29	33	12	M6x0.75	6	10	6	11	
LH25AN	40				M6x1x9																	
LH25BL	36				M6x1x6																	
LH25BN	40				M6x1x9																	
LH30AL	42	9	16	60	85.6	40	40	M8x1.25x8	10	59	9.5	33	36	33	36	14	M6x0.75	7	10	7	11	
LH30AN	45				M8x1.25x10																	
LH30BL	42				M8x1.25x8																	
LH30BN	45				M8x1.25x10																	
LH35AL	48	9.5	18	70	109	50	72	M8x1.25x8	10	80	15	38.5	45.5	38.5	45.5	15	M6x0.75	8	15	8	11	
LH35AN	55				M8x1.25x12																	
LH35BL	48				M8x1.25x8																	
LH35BN	55				M8x1.25x12																	
LH45AN	70	14	20.5	86	139	60	60	M10x1.5x17	13	105	22.5	56	17	Rc1/8	20	13						
LH45BN					171		80			137	28.5											
LH55AN	80	15	23.5	100	163	75	75	M12x1.75x18	12.5	126	25.5	65	18	Rc1/8	21	13						
LH55BN					201		95			164	34.5											
LH65AN	90	16	31.5	126	193	76	70	M16x2x20	25	147	38.5	74	23	Rc1/8	19	13						
LH65BN					253		120			207	43.5											

BL型
BN型

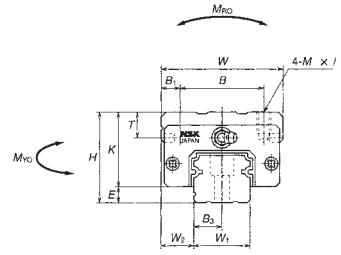
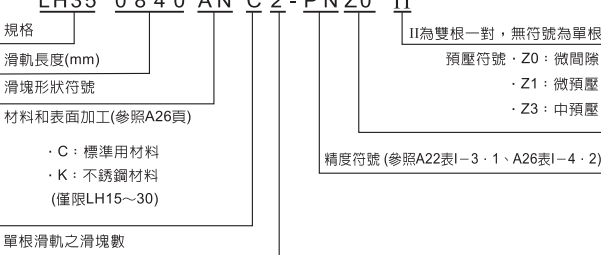
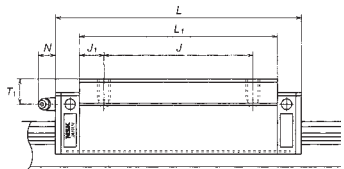

AL型
AN型

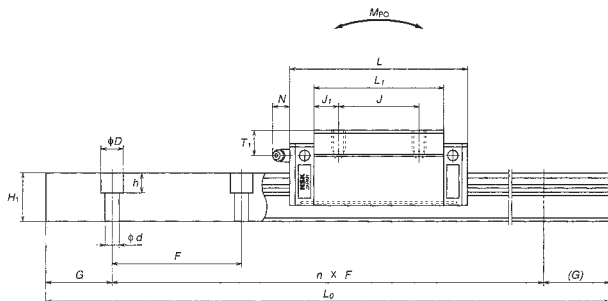

單位：mm

滑軌尺寸						基本額定負載					滾珠直徑	重量		
滑軌寬	滑軌高	間距	安裝螺栓孔	B_3	G (推薦)	最大長度 L_{omax} <small>(1) 均為不銹鋼</small>	動態額定值 C	靜態額定值 C_0	靜態力矩			D_w	滑塊 (Kg)	滑軌 (Kg/m)
W_1	H_1	F	$d \times D \times h$				(N)	M_{RO}	M_{PO}	M_{YO}	(N·m)			
15	15	60	4.5×7.5×5.3	7.5	20	2000 (1800)	10800	20700	108	95	80	3.175	0.18	1.6
							14600	32000	166	216	181		0.26	
20	18	60	6×9.5×8.5	10	20	3960 (3500)	17400	32500	219	185	155	3.968	0.33	2.6
							23500	50500	340	420	355		0.48	
23	22	60	7×11×9	11.5	20	3960 (3500)	25600	46000	360	320	267	4.762	0.55	3.6
							34500	71000	555	725	610		0.82	
28	26	80	9×14×12	14	20	4000 (3500)	31000	51500	490	350	292	5.556	0.77	5.2
							46000	91500	870	1030	865		1.3	
34	29	80	9×14×12	17	20	4000	47500	80500	950	755	630	6.350	1.5	7.2
							61500	117000	1380	1530	1280		2.1	
45	38	105	14×20×17	22.5	22.5	3990	81000	140000	2140	1740	1460	7.937	3.0	12.3
							99000	187000	2860	3000	2520		3.9	
53	44	120	16×23×20	26.5	30	3960	119000	198000	3600	3000	2510	9.525	4.7	16.9
							146000	264000	4850	5150	4350		6.1	
63	53	150	18×26×22	31.5	35	3900	181000	281000	6150	4950	4150	11.906	7.7	24.3
							253000	410000	8950	10100	8450		10.8	

LH系列 (預壓保證品)

LH-EL (大負載型)

LH-GL (超大負載型)

· 預壓保證品的連絡編號 (訂貨生產)



表 I-5 · 2

規格	組裝品尺寸			滑塊尺寸												
	高度 H	E	W ₂	寬度 W	長度 L	安裝螺絲孔			B ₁	L ₁	J ₁	K	T	油嘴		
						B	J	M×間距×l						安裝孔	T ₁	N
LH15EL	24	4.6	16	47	55	38	30	M5×0.8×8	4.5	39	4.5	19.4	8	φ3	4.5	3.3
LH15GL					74					58	14					
LH20EL	30	5	21.5	63	69.8	53	40	M6×1×10	5	50	5	25	10	M6×0.75	5	11
LH20GL					91.8											
LH25EL	36	7	23.5	70	79	57	45	M8×1.25×16 (M8×1.25×12)	6.5	58	6.5	29	11 (12)	M6×0.75	6	11
LH25GL					107											
LH30EL	42	9	31	90	98.6	72	52	M10×1.5×18 (M10×1.5×15)	9	72	10	33	11 (15)	M6×0.75	7	11
LH30GL					124.6											
LH35EL	48	9.5	33	100	109	82	62	M10×1.5×20	9	80	9	38.5	12	M6×0.75	8	11
LH35GL					143											
LH45EL	60	14	37.5	120	139	100	80	M12×1.75×24	10	105	12.5	46	13	Rc1/8	10	13
LH45GL					171											
LH55EL	70	15	43.5	140	163	116	95	M14×2×28	12	126	15.5	55	15	Rc1/8	11	13
LH55GL					201											
LH65EL	90	16	53.5	170	193	142	110	M16×2×24	14	147	18.5	74	23	Rc1/8	19	13
LH65GL					253											
LH85GL	110	18	65	215	303	185	140	M20×2.5×30	15	243	51.5	92	30	Rc1/8	23	13

括號內的尺寸適用於不銹鋼品。
 LH85為訂貨生產之產品。

GL型

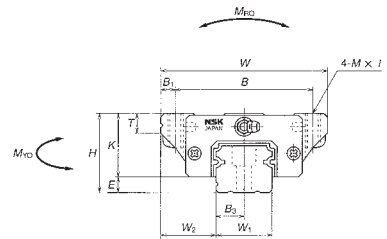
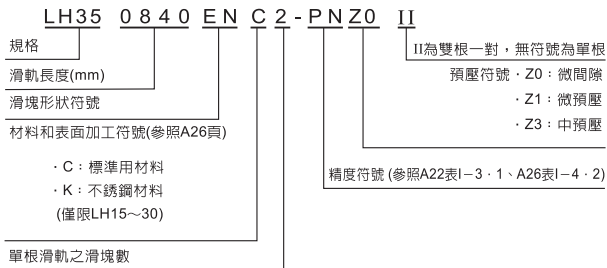
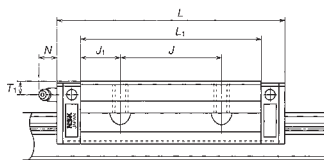

EL型

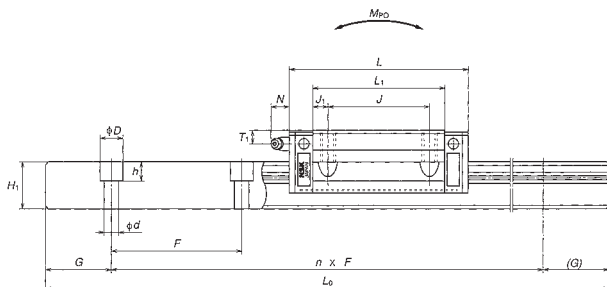

單位：mm

滑軌寬 W_1	滑軌尺寸					基本額定負載					滾珠直徑 D_w	重量		
	滑軌高 H_1	間距 F	安裝螺栓孔 $d \times D \times h$	B_3	G (推薦)	最大長度 L_{omax} (1) 內裝 SUS	靜態額定值			D_w		滑塊 (Kg)	滑軌 (Kg/m)	
							動態額定值 C	靜態額定值 C_0	靜態力矩 M_{RO} M_{PO} M_{YO} (N·m)					
15	15	60	4.5×7.5×5.3	7.5	20	2000 (1800)	10800	20700	108	95	80	3.175	0.17	1.6
							14600	32000	166	216	181		0.25	
20	18	60	6×9.5×8.5	10	20	3960 (3500)	17400	32500	219	185	155	3.968	0.45	2.6
							23500	50500	340	420	355		0.65	
23	22	60	7×11×9	11.5	20	3960 (3500)	25600	46000	360	320	267	4.762	0.63	3.6
							34500	71000	555	725	610		0.93	
28	26	80	9×14×12	14	20	4000 (3500)	35500	63000	600	505	425	5.556	1.2	5.2
							46000	91500	870	1030	865		1.6	
34	29	80	9×14×12	17	20	4000	47500	80500	950	755	630	6.350	1.7	7.2
							61500	117000	1380	1530	1280		2.4	
45	38	105	14×20×17	22.5	22.5	3990	81000	140000	2140	1740	1460	7.937	3.0	12.3
							99000	187000	2860	3000	2520		3.9	
53	44	120	16×23×20	26.5	30	3960	119000	198000	3600	3000	2510	9.525	5.0	16.9
							146000	264000	4850	5150	4350		6.5	
63	53	150	18×26×22	31.5	35	3900	181000	281000	6150	4950	4150	11.906	10.0	24.3
							235000	410000	8950	10100	8450		14.1	
85	65	180	24×35×28	42.5	45	2520	345000	585000	17300	17400	14600	14.287	24.5	38.3

LH系列(預壓保證品)

LH-EM (大負載型)
 LH-FL (超大大負載型)
 LH-GM (超大大負載型)
 LH-HL (超大大負載型)

· 預壓保證品的連絡編號(訂貨生產)



表 I-5 · 3

規格	組裝品尺寸				滑塊尺寸												
	高度 H	E	W ₂	寬度 W	長度 L	安裝螺絲孔				B ₁	L ₁	J ₁	K	T	油嘴		
						B	J	Q ₁ x l	Q ₂						安裝孔	T ₁	N
LH15FL	24	4.6	16	47	55	38	30	4.5x7	-	4.5	39	4.5	19.4	8	φ3	4.5	3.3
LH15EM					74			M5x0.8x7	4.4								
LH15HL					74			4.5x7	-								
LH15GM	30	5	21.5	63	69.8	53	40	M5x0.8x7	4.4	5	58	14	25	10	M6x0.75	5	11
LH20FL					91.8			6x9.5	-								
LH20EM					91.8			M6x1x9.5	5.3								
LH20HL	36	7	23.5	70	79	57	45	6x9.5	-	6.5	58	6.5	29	11 (12)	M6x0.75	6	11
LH25EM					107			M6x1x9.5	5.3								
LH25HL					107			6x9.5	-								
LH25GM	42	9	31	90	98.6	72	52	7x10(7x11.5)	-	9	72	10	33	11 (15)	M6x0.75	7	11
LH30FL					124.6			M8x1.25x10	6.8								
LH30EM					124.6			(M8x1.25x11.5)	6.8								
LH30HL	48	9.5	33	100	109	82	62	7x10(7x11.5)	-	9	80	9	38.5	12	M6x0.75	8	11
LH35FL					143			M8x1.25x10	6.8								
LH35EM					143			(M8x1.25x11.5)	6.8								
LH35HL	60	14	37.5	120	139	100	80	9x12(9x14.5)	-	10	105	12.5	46	13	Rc1/8	10	13
LH45FL					171			M10x1.5x12	8.6								
LH45EM					171			(M10x1.5x14.5)	8.6								
LH45HL	70	15	43.5	140	163	116	95	9x12(9x14.5)	-	12	126	15.5	55	15	Rc1/8	11	13
LH55FL					201			M10x1.5x13	8.6								
LH55EM					201			(M10x1.5x14.5)	8.6								
LH55HL	90	16	53.5	170	193	142	110	11x15	-	14	147	18.5	74	23	Rc1/8	19	13
LH65FL					263			M12x1.75x15	10.5								
LH65EM					263			(M12x1.75x15)	10.5								
LH65HL	110	18	65	215	303	185	140	14x18	-	15	243	51.5	92	30	Rc1/8	23	13
LH85FL					303			M14x2.0x18	12.5								
LH85EM					303			(M14x2.0x18)	12.5								
LH85HL	110	18	65	215	303	185	140	16x24	-	15	243	51.5	92	30	Rc1/8	23	13
LH85FL					303			M16x2.0x24	14.6								
LH85EM					303			(M16x2.0x24)	14.6								
LH85HL	110	18	65	215	303	185	140	16x24	-	15	243	51.5	92	30	Rc1/8	23	13
LH85FL					303			M16x2.0x24	14.6								
LH85EM					303			(M16x2.0x24)	14.6								

括號內的尺寸適用於不銹鋼品。
 LH85為訂貨生產之產品。

GM型
HL型

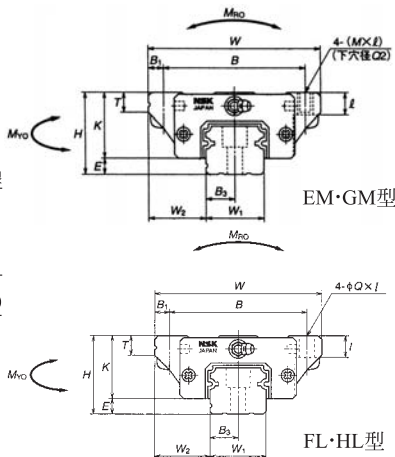
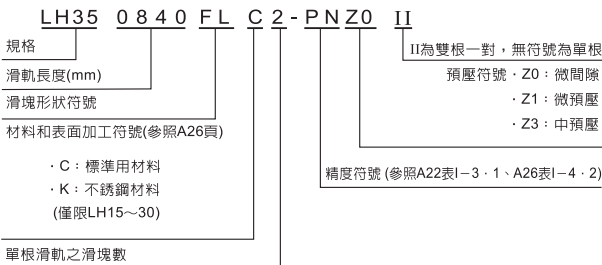
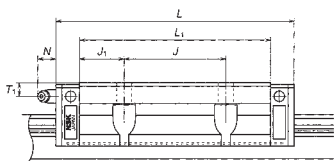

EM型
FL型

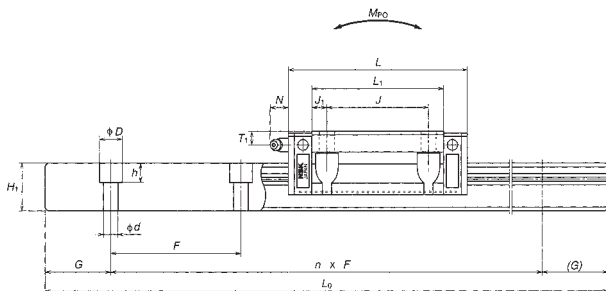

單位：mm

滑軌尺寸						基本額定負載					滾珠直徑	重量		
滑軌寬	滑軌高	間距	安裝螺栓孔	B_3	G (推薦)	最大長度 L_{omax} (1)內徑SUS	動態額定值 C	靜態額定值 C_0	靜態力矩 M_{RO} M_{PO} M_{VO} (N·m)			D_w	滑塊 (Kg)	滑軌 (Kg/m)
W_1	H_1	F	$d \times D \times h$				(N)							
15	15	60	4.5×7.5×5.3	7.5	20	2000 (1800)	10800	20700	108	95	80	3.175	0.17	1.6
							14600	32000	166	216	181		0.25	
20	18	60	6×9.5×8.5	10	20	3960 (3500)	17400	32500	219	185	155	3.968	0.45	2.6
							23500	50500	340	420	355		0.65	
23	22	60	7×11×9	11.5	20	3960 (3500)	25600	46000	360	320	267	4.762	0.63	3.6
							34500	71000	555	725	610		0.93	
28	26	80	9×14×12	14	20	4000 (3500)	35500	63000	600	505	425	5.556	1.2	5.2
							46000	91500	870	1030	865		1.6	
34	29	80	9×14×12	17	20	4000	47500	80500	950	755	630	6.350	1.7	7.2
							61500	11700	1380	1530	1280		2.4	
45	38	105	14×20×17	22.5	22.5	3990	81000	140000	2140	1740	1460	7.937	3.0	12.3
							99000	187000	2860	3000	2520		3.9	
53	44	120	16×23×20	26.5	30	3960	119000	198000	3600	3000	2510	9.525	5.0	16.9
							146000	264000	4850	5150	4350		6.5	
63	53	150	18×26×22	31.5	35	3900	181000	281000	6150	4950	4150	11.906	10.0	24.3
							235000	410000	8950	10100	8450		14.1	
85	65	180	24×35×28	42.5	45	2520	345000	585000	17300	17400	14600	14.287	24.5	38.3

LH系列 (互換性產品)

LH系列尺寸表 (互換性產品)

LAH-AL (大負載型)
 LAH-AN (大負載型)
 LAH-BL (超大負載型)
 LAH-BN (超大負載型)

· 請參照A27頁的互換性單體產品之公稱型號。



表 I-5.4

規格	組裝品尺寸			滑塊尺寸									
	高度 <i>H</i>	<i>E</i>	<i>W</i> ₂	寬度 <i>W</i>	長度 <i>L</i>	安裝螺絲孔			<i>B</i>	<i>L</i> ₁	<i>J</i> ₁	<i>K</i>	<i>T</i>
						<i>B</i>	<i>J</i>	<i>M</i> ×間距× <i>l</i>					
LAH15AN LAH15BN	28	4.6	9.5	34	55 74	26	26	M4x0.7x6	4	39 58	6.5 16	23.4	8
LAH20AN LAH20BN	30	5	12	44	69.8 91.8	32	36 50	M5x0.8x6	6	50 72	7 11	25	12
LAH25AL LAH25AN LAH25BL LAH25BN	36 40 36 40	7	12.5	48	79 107	35	35 50	M6x1x6 M6x1x9 M6x1x6 M6x1x9	6.5	58 86	11.5 18	29 33 29 33	12
LAH30AL LAH30AN LAH30BL LAH30BN	42 45 42 45	9	16	60	85.6 124.6	40	40 60	M8x1.25x8 M8x1.25x10 M8x1.25x8 M8x1.25x10	10	59 98	9.5 19	33 36 33 36	14
LAH35AL LAH35AN LAH35BL LAH35BN	48 55 48 55	9.5	18	70	109 143	50	50 72	M8x1.25x8 M8x1.25x12 M8x1.25x8 M8x1.25x12	10	80 114	15 21	38.5 45.5 38.5 45.5	15
LAH45AN LAH45BN	70	14	20.5	86	139 171	60	60 80	M10x1.5x17	13	105 137	22.5 28.5	56	17
LAH55AN LAH55BN	80	15	23.5	100	163 201	75	75 95	M12x1.75x18	12.5	126 164	25.5 34.5	65	18
LAH65AN LAH65BN	90	16	31.5	126	193 253	76	70 120	M16x2x20	25	147 207	38.5 48.5	74	23

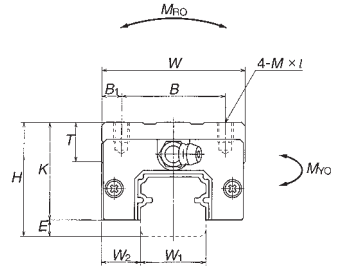

AL型
AN型

BL型
BN型

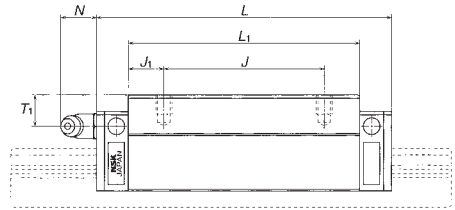
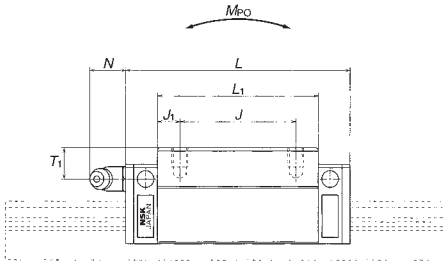

單位 : mm

潤滑油脂注油孔			基本額定負載					滾珠直徑	重量
安裝孔	T_1	N	動態額定值	靜態額定值	靜態力矩			D_w	滑塊 (Kg)
			C	C_0	M_{RO}	M_{PO}	M_{VO}		
φ3	8.5	3.3	10800	20700	108	95	80	3.175	0.18
			14600	32000	166	216	181		0.26
M6×0.75	5	11	17400	32500	219	185	155	3.968	0.33
			23500	50500	340	420	355		0.48
M6×0.75	10	11	25600	46000	360	320	267	4.762	0.55
			34500	71000	555	725	610		0.82
M6×0.75	10	11	35500	63000	600	505	425	5.556	0.77
			46000	91500	870	1030	865		1.3
M6×0.75	15	11	47500	80500	950	755	630	6.350	1.5
			61500	117000	1380	1530	1280		2.1
Rc1/8	20	13	81000	140000	2140	1740	1460	7.937	3.0
			99000	187000	2860	3000	2520		3.9
Rc1/8	21	13	119000	198000	3600	3000	2510	9.525	4.7
			146000	264000	4850	5150	4350		6.1
Rc1/8	19	13	181000	281000	6150	4950	4150	11.906	7.7
			235000	410000	8950	10100	8450		10.8

LH系列 (互換性產品)

LAH-EL (大負載型)

LAH-GL (超大負載型)

· 請參照A27頁的互換性單體產品之公稱型號。



表 1-5 · 5

規格	組裝品尺寸			滑塊尺寸									
	高度 H	E	W_2	寬度 W	長度 L	安裝螺絲孔			B_1	L_1	J_1	K	T
						B	J	$M \times \text{間距} \times l$					
LAH15EL	24	4.6	16	47	55	38	30	M5×0.8×8	4.5	39	4.5	19.4	8
LAH15GL					74					58	14		
LAH20EL	30	5	21.5	63	69.8	53	40	M6×1×10	5	50	5	25	10
LAH20GL					91.8					72	16		
LAH25EL	36	7	23.5	70	79	57	45	M8×1.25×16 (M8×1.25×12)	6.5	58	6.5	29	11
LAH25GL					107					86	20.5		
LAH30EL	42	9	31	90	98.6	72	52	M10×1.5×18 (M10×1.5×15)	9	72	10	33	11
LAH30GL					124.6					98	23		
LAH35EL	48	9.5	33	100	109	82	62	M10×1.5×20	9	80	9	38.5	12
LAH35GL					143					114	26		
LAH45EL	60	14	37.5	120	139	100	80	M12×1.75×24	10	105	12.5	46	13
LAH45GL					171					137	28.5		
LAH55EL	70	15	43.5	140	163	116	95	M14×2×28	12	126	15.5	55	15
LAH55GL					201					164	34.5		
LAH65EL	90	16	53.5	170	193	142	110	M16×2×24	14	147	18.5	74	23
LAH65GL					253					207	48.5		

括號內的尺寸適用於不銹鋼品。

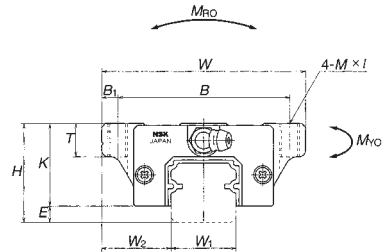
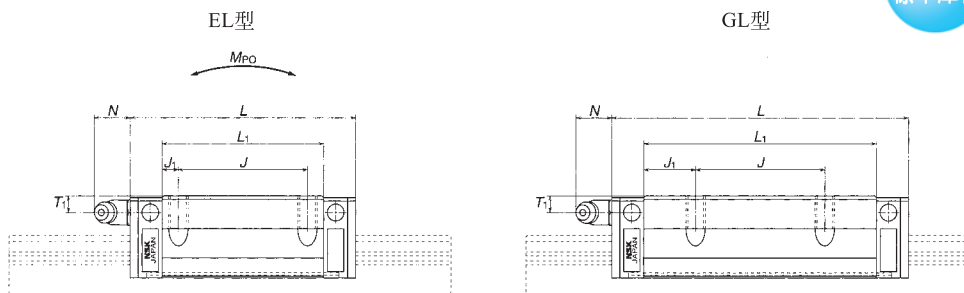

單位：mm

潤滑油脂注油孔			基本額定負載					滾珠直徑	重量
			動態額定值	靜態額定值	靜態力矩				
安裝孔	T_1	N	C	C_0	M_{RO}	M_{PO}	M_{YO}	D_w	滑塊 (Kg)
			(N)			(N·m)			
φ3	4.5	3.3	10800	20700	108	95	80	3.175	0.17
			14600	32000	166	216	181		0.25
M6×0.75	5	11	17400	32500	219	185	155	3.968	0.45
			23500	50500	340	420	355		0.65
M6×0.75	6	11	25600	46000	360	320	267	4.762	0.63
			34500	71000	555	725	610		0.93
M6×0.75	7	11	35500	63000	600	505	425	5.556	1.2
			46000	91500	870	1030	865		1.6
M6×0.75	8	11	47500	80500	950	755	630	6.350	1.7
			61500	117000	1380	1530	1280		2.4
Rc1/8	10	13	81000	140000	2140	1740	1460	7.937	3.0
			99000	187000	2860	3000	2520		3.9
Rc1/8	11	13	119000	198000	3600	3000	2510	9.525	5.0
			146000	264000	4850	5150	4350		6.5
Rc1/8	19	13	181000	281000	6150	4950	4150	11.906	10.0
			235000	410000	8950	10100	8450		14.1

LH系列 (互換性產品)

LAH-EM (大負載型)
 LAH-FL (大負載型)
 LAH-HL (超大負載型)
 LAH-GM (超大負載型)

· 請參照A27頁的互換性單體產品之公稱型號。



表 I-5-6

規格	組裝品尺寸			滑塊尺寸										
	高度 H	E	W ₂	寬度 W	長度 L	安裝螺絲孔				B ₁	L ₁	J ₁	K	T
						B	J	Q, x ℓ M:間距xℓ	Q ₂					
LAH15FL LAH15EM LAH15HL LAH15GM	24	4.6	16	47	55 74	38	30	4.5x7 M5x0.8x7 4.5x7 M5x0.8x7	4.4 — 4.4	4.5	39 58	4.5 14	19.4	8
LAH20FL LAH20EM LAH20HL LAH20GM	30	5	21.5	63	69.8 91.8	53	40	6x9.5 M6x1x9.5 6x9.5 M6x1x9.5	5.3 — 5.3	5	50 72	5 16	25	10
LAH25FL LAH25EM LAH25HL LAH25GM	36	7	23.5	70	79 107	57	45	7x10(7x11.5) M8x1.25x10 (M8x1.25x11.5) 7x10(7x11.5) M8x1.25x10 (M8x1.25x11.5)	— 6.8 — 6.8	6.5	58 86	6.5 20.5	29	11 (12)
LAH30FL LAH30EM LAH30HL LAH30GM	42	9	31	90	98.6 124.6	72	52	9x12(9x14.5) M10x1.5x12 (M10x1.5x14.5) 9x12(9x14.5) M10x1.5x12 (M10x1.5x14.5)	— 8.6 — 8.6	9	72 98	10 23	33	11 (15)
LAH35FL LAH35EM LAH35HL LAH35GM	48	9.5	33	100	109 143	82	62	9x13 M10x1.5x13 9x13 M10x1.5x13	8.6 — 8.6	9	80 114	9 26	38.5	12
LAH45FL LAH45EM LAH45HL LAH45GM	60	14	37.5	120	139 171	100	80	11x15 M12x1.75x15 11x15 M12x1.75x15	— 10.5 — 10.5	10	105 137	12.5 28.5	46	13
LAH55FL LAH55EM LAH55HL LAH55GM	70	15	43.5	140	163 201	116	95	14x18 M14x2.0x18 14x18 M14x2.0x18	— 12.5 — 12.5	12	126 164	15.5 34.5	55	15
LAH65FL LAH65EM LAH65HL LAH65GM	90	16	53.5	170	193 263	142	110	16x24 M16x2.0x24 16x24 M16x2.0x24	— 14.6 — 14.6	14	147 207	18.5 48.5	74	23
LAH85HL	110	18	65	215	303	185	140	18x30	—	15	243	51.5	92	30

括號內的尺寸適用於不銹鋼品。

EM型
FL型

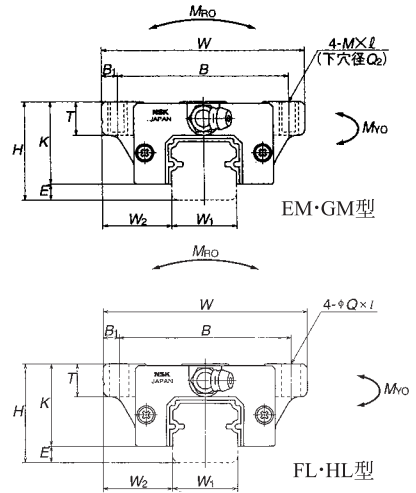
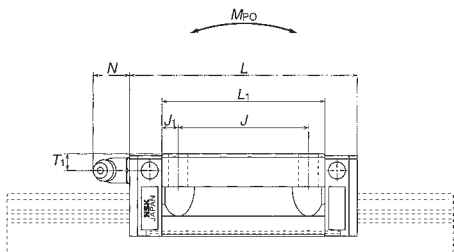

GM型
HL型

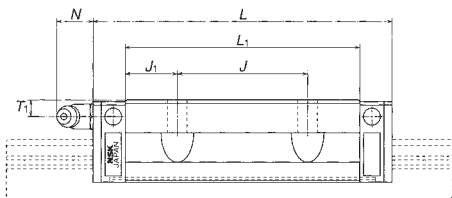

單位：mm

潤滑油脂注油孔			基本額定負載					滾珠直徑 D_w	重量 滑塊 (Kg)
安裝孔	T_1	N	動態額定值	靜態額定值	靜態力矩				
			C	C_0 (N)	M_{RO}	M_{PO} (N·m)	M_{VO}		
φ3	4.5	3.3	10800	20700	108	95	80	3.175	0.17
			14600	32000	166	216	181		0.25
M6x0.75	5	11	17400	32500	219	185	155	3.968	0.45
			23500	50500	340	420	355		0.65
M6x0.75	6	11	25600	46000	360	320	267	4.762	0.63
			34500	71000	555	725	610		0.93
M6x0.75	7	11	35500	63000	600	505	425	5.556	1.2
			46000	91500	870	1030	865		1.6
M6x0.75	8	11	47500	80500	950	755	630	6.35	1.7
			61500	117000	1380	1530	1280		2.4
Rc1/8	10	13	81000	140000	2140	1740	1460	7.937	3
			99000	187000	2860	3000	2520		3.9
Rc1/8	11	13	119000	198000	3600	3000	2510	9.525	5
			146000	264000	4850	5150	4350		6.5
Rc1/8	19	13	181000	281000	6150	4950	4150	11.906	10
			235000	410000	8950	10100	8450		14.1
Rc1/8	23	13	345000	585000	17300	17400	14600	14.287	24.5



LH系列的滑軌尺寸表(互換性產品)

公稱型號示例

普通滑軌 (非對接滑軌)時：

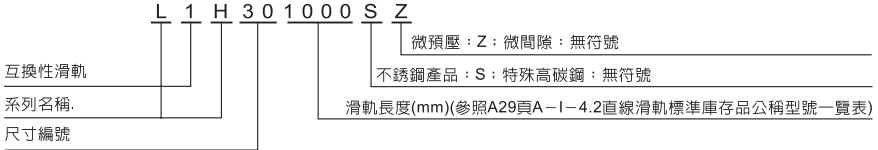

有關對接滑軌的事宜，請向NSK諮詢。

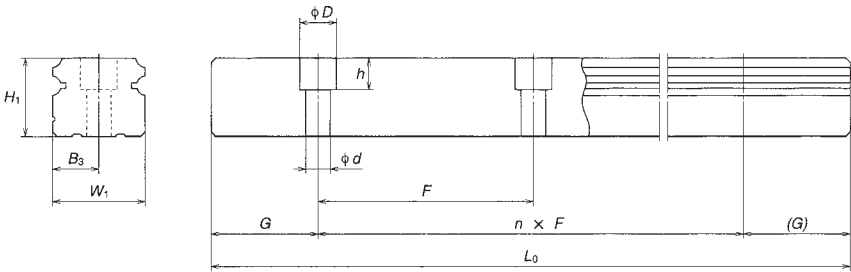

表 1-5-7

單位：mm

規格	滑軌尺寸							重量 滑軌 (Kg/m)
	滑軌寬 W_1	滑軌高 H_1	間距 F	安裝螺柱孔 $d \times D \times h$	B_3	G (推薦)	最大長度 L_{max}	
L1H15	15	15	60	4.5×7.5×5.3	7.5	20	2000	1.6
L1H20	20	18	60	6×9.5×8.5	10	20	3960	2.6
L1H25	23	22	60	7×11×9	11.5	20	3960	3.6
L1H30	28	26	80	9×14×12	14	20	4000	5.2
L1H35	34	29	80	9×14×12	17	20	4000	7.2
L1H45	45	38	105	14×20×17	22.5	22.5	3990	12.3
L1H55	53	44	120	16×23×20	26.5	30	3960	16.9
L1H65	63	53	150	18×26×22	31.5	35	3900	24.3

對接滑軌的規格，G尺寸為1/2F-0.5。