

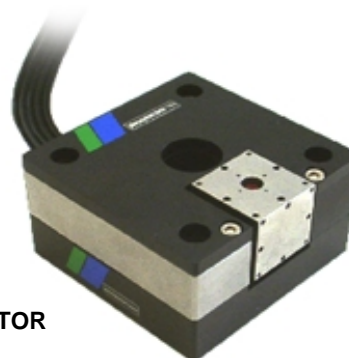

PENTOR – 5-axis system

150V

- combination of a three axis translation system and a two axis tilting system
- free center hole with 17mm diameter
- integrated preload
- translation each axis: 100µm
- tilt each direction: ± 2.5 mrad
- solid state flexure hinges in parallelogram design without mechanical play
- optional measurement system



PENTOR

applications:

- object handling in microscopes
- scanning system
- micropositioning use
- dynamical applications
- laser tuning / alignment
- optical stages

Optical stages often require an open central space (e.g. for passing light). For such applications, the new translation and tilting system PENTOR was developed with a 17 mm free center hole.

It offers a motion in XYZ of 100µm and a tilt of ± 2.5 mrad on two orthogonal axes. Flexure hinges for the three translation axes guarantee the highest degree of parallelism over the travel range of the stage. Each axis has an integrated mechanical preload, making the new PENTOR system very well suited for dynamic applications.

The tilting part is designed for "plus-minus tilting." Their construction is temperature compensated: changes in the surrounding temperature do not affect the tilting angle. Because the mirror mounts are preloaded, and are characterized by high stiffness and resonant frequency, dynamic operation is a possible application.

Main parts with solid state flexure hinges are made from stainless steel. The bottom and the top plate are made from black-anodized aluminum.

As an option, the PENTOR can be offered with an integrated strain gauge measurement system.

PENTOR part no.		unit	PENTOR T-450-00	PENTOR SG T-450-01	PENTOR SG DIG T-450-01
operating voltage		V	-10 to +150	-10 to +150	-10 to +150
dimensions	length L	mm	69	69	69
	width B	mm	68	68	68
	height H	mm	40	40	40
free center space		mm	17	17	17
distance of drills		mm	50 (M4)	50 (M4)	50 (M4)
temperature range		°C	-20 to 80	-20 to 80	-20 to 80
max. load		N	50	50	50
cable length		m	1	1.2	1.2
weight		g	450	480	480
translation stage					
motion ± 10% x,y,z		µm	100	80	80
capacitance (each axis) ±20%		µF	1.7	1.7	1.7
resonant	x-axis	Hz	680	680	680
	y-axis	Hz	750	750	750
	z-axis	Hz	580	580	580
stiffness (each axis)		N/µm	0.5	0.5	0.5
typ. non-linearity		%	-	0.03	0.03
typ. repeatability		nm	-	25	25
connector	voltage	-	LEMO 0S.303	LEMO 0S.303	LEMO 0S.303
	sensor	-	-	LEMO 0S.303	LEMO 0S.303
tilting stage					
tilt (± 10%) Θx, Θy		mrad	± 2.5	± 2	± 2
operating voltage		V	-10 to +150	-10 to +150	-10 to +150
number of axis		-	2	2	2
capacitance (per axis) ± 20%		µF	2 x 0.85	2 x 0.85	2 x 0.85
typ. non-linearity		%	-	0.35	0.35
typ. repeatability		nm	-	5	5
connector	voltage	-	LEMO 0S.303	LEMO 0S.303	LEMO 0S.303
	sensor	-	-	LEMO 0S.303	LEMO 0S.303
pivot point – center of the stage, 4 mm below top plate					

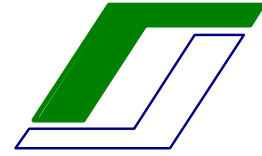

options:

integrated measurement system, vacuum option, low temperature option, different tilting planes

option: different tilting planes

The tilting axes of the PENTOR can be used in different tilting planes depending on the mounting of the actuator (picture 1-3). The upright setup is realized by 2 mounting threads at the sides of the PENTOR or by an adapter plate (Z-700-00).

To get the best cable duct on each actuator position and on each setup 3 variations of the PENTOR are available:

T-450-00	PENTOR 100/5 ;	cable duct in the back (picture 1)
T-451-00	PENTOR 100/5 R;	cable duct on the left (picture 2)
T-452-00	PENTOR 100/5 L;	cable duct on the right (picture 3)
T-451-00+ Z-700-00	PENTOR 100/R;	cable duct on the right with adapter plate (picture 4)
T-452-00+ Z-700-00	PENTOR 100/5 L;	cable duct on the left with adapter plate (picture 5)

Please be sure to order the right variation of the PENTOR. Later changes are possible but they will cause additional costs.

PENTOR, horizontal setup

picture 1:
PENTOR T-450-00, horizontal setup

Of course the optional cable duct (picture 2 and 3) can also be used in the horizontal setup. So an optimal integration of the cable into the whole stage can be realized.

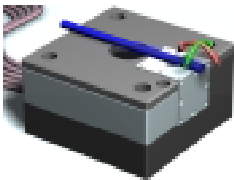

PENTOR, horizontal setup

picture 2
PENTOR T-451-00, cable duct on the right

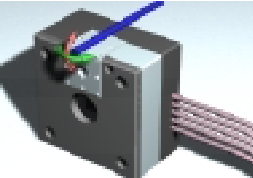

picture 3
PENTOR T-452-00, cable duct on the left

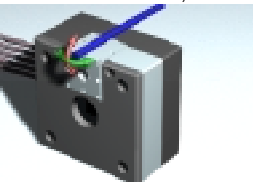

control electronics:

There are specially arranged electronics available for the PENTOR elements. Our sales crew is happy to give you detailed information.

adapter plate for the upright setup

The adapter plate allows an easy fixing of the PENTOR (e.g. directly on an optical table).



**example for comined systems:
PENTOR and a fiber holder**

adapter plate Z-700-00

Using the adapter plate allows an easy assembling of the PENTOR systems. The PENTOR can be fixed on two different ways: (picture 4 and 5).

picture 4
PENTOR T-451-00, Z-700-00; cable duct on the right

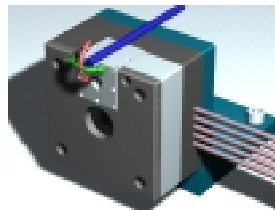

picture 5 PENTOR T-452-00, Z-700-00; cable duct on the left

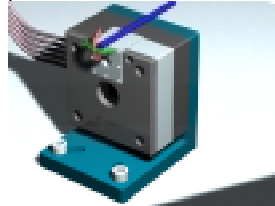

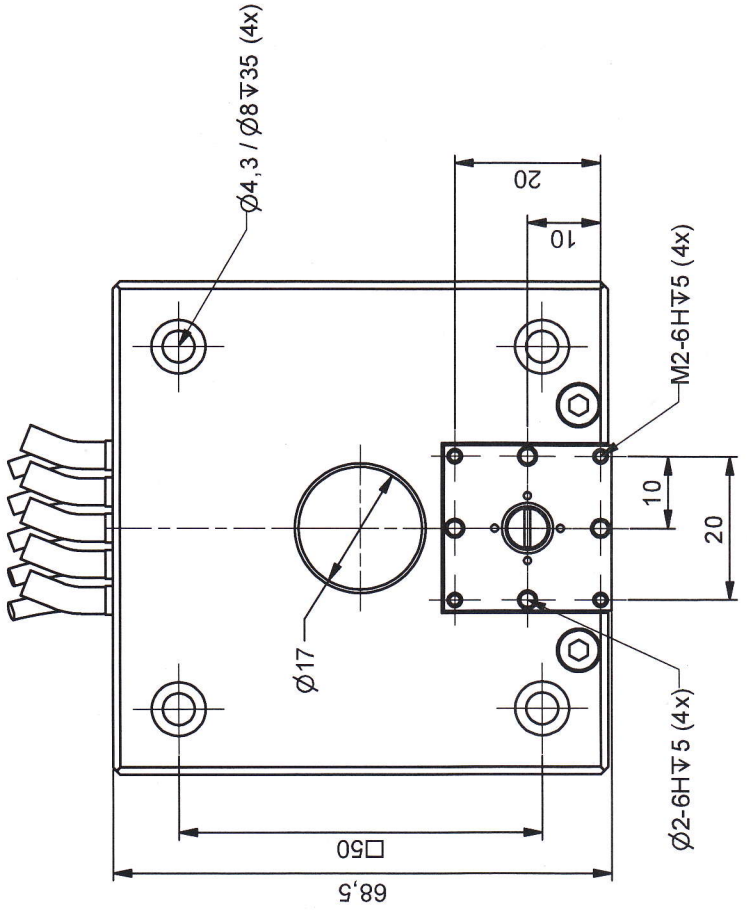
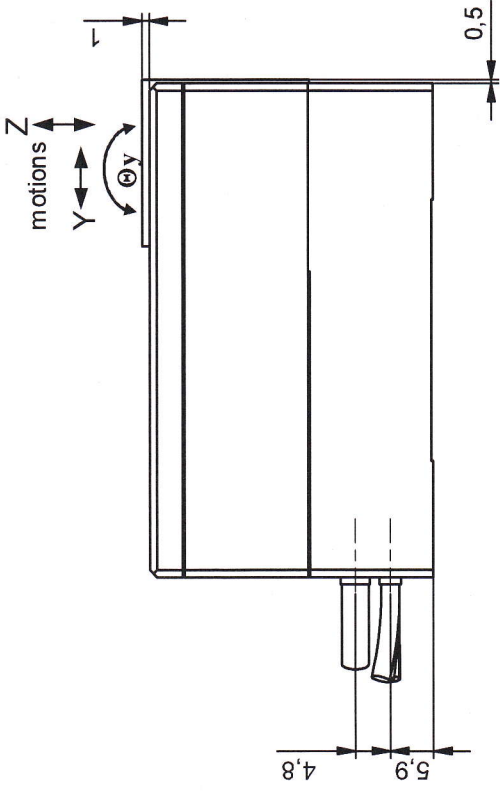
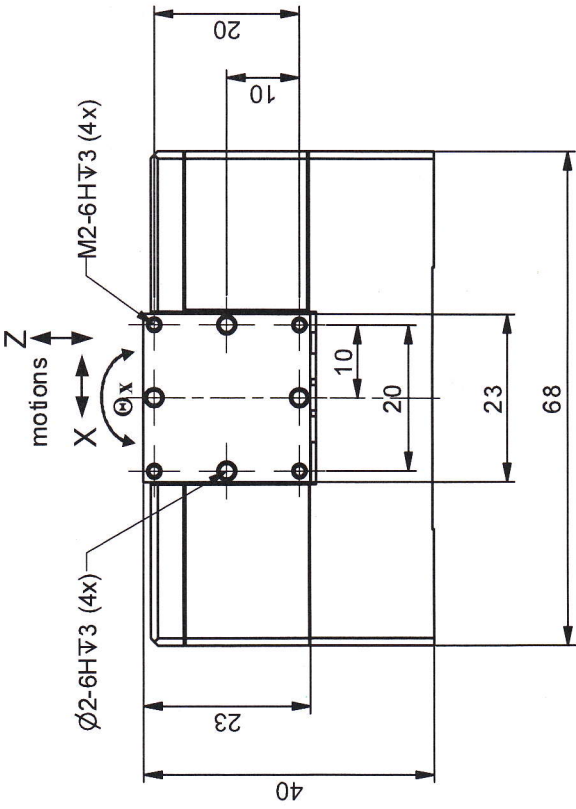

(1:2)

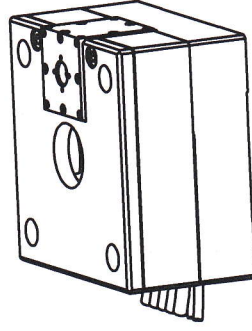

ORIGINAL

part.-no.	T-450-01	part.-name	Pentor SG
file name	PT45001	OK date/sign.	2. JAN 2010
		scale	1:1
		customers drawing	piezosystem jena